

1 Test Summary

EMISSION				
Test Item	Test Standard	Class / Severity	Result	
Mains Terminal Disturbance Voltage, 9kHz to 30MHz	EN 55015:2013+A1:2015	Clause 4.3.1	N/A	
Radiated electromagnetic disturbance, 9kHz to 30MHz	EN 55015:2013+A1:2015	Clause 4.4.1	Pass	
Radiated Emission, 30MHz to 300MHz	EN 55015:2013+A1:2015	Clause 4.4.2	Pass	
IMMUNITY (EN 61547: 2009)				
Test Item	Test Method	Class / Severity	Performance Criteria	Result
Electrostatic Discharge(ESD)	IEC 61000-4-2:2008	±4 kV Contact ±8 kV Air	B	Pass
Radio-frequency electromagnetic fields (80MHz to 1GHz)	IEC 61000-4-3:2010	3V/m, 80%, 1kHz, Amp. Mod.	A	Pass
Electrical Fast Transients (EFT)	IEC 61000-4-4:2012	AC ±1.0kV DC ±0.5kV	B	N/A
Surge	IEC 61000-4-5:2005	±1kV D.M.† ±2kV C.M.‡	C	N/A
Injected Currents, 0.15MHz to 80MHz	IEC 61000-4-6:2013	3Vr.m.s.(emf), 80%, 1kHz Amp. Mod.	A	N/A
Power-frequency magnetic field	IEC 61000-4-8:2009	3A/m	A	N/A
Voltage Dips and Interruptions	IEC 61000-4-11:2004	0 % UT* for 0.5per	B	N/A
		70 % UT* for 10per	C	N/A

Remark:

Pass	Test item meets the requirement
Fail	Test item does not meet the requirement
N/A	Test case does not apply to the test object
A.M	Amplitude Modulation
†	Differential Mode
‡	Common Mode
*	U _T is the nominal supply voltage

2	Contents	Page
	COVER PAGE	1
1	TEST SUMMARY	2
2	CONTENTS	3
3	GENERAL INFORMATION	4
3.1	GENERAL DESCRIPTION OF E.U.T.	4
3.2	DETAILS OF E.U.T.	4
3.3	DESCRIPTION OF SUPPORT UNITS	4
3.4	STANDARDS APPLICABLE FOR TESTING	4
3.5	TEST FACILITY	5
3.6	SUBCONTRACTED	5
3.7	ABNORMALITIES FROM STANDARD CONDITIONS	5
4	EQUIPMENT USED DURING TEST	6
4.1	MEASUREMENT UNCERTAINTY	7
5	EMISSION TEST RESULTS	8
5.1	RADIATED ELECTROMAGNETIC DISTURBANCE, 9KHZ TO 30MHZ	8
5.1.1	<i>E.U.T. Operation</i>	8
5.1.2	<i>Block Diagram of Test Setup</i>	9
5.1.3	<i>Measurement Data</i>	9
5.1.4	<i>Radiated Electromagnetic Disturbance test data, 9kHz to 30MHz</i>	10
5.2	RADIATED EMISSION, 30MHZ TO 300MHZ	13
5.2.1	<i>E.U.T. Operation</i>	13
5.2.2	<i>Block Diagram of Setup</i>	13
5.2.3	<i>Measurement Data</i>	14
5.2.4	<i>Radiated Emission Test Data</i>	14
6	IMMUNITY TEST RESULTS	16
6.1	PERFORMANCE CRITERIA	16
6.2	ELECTROSTATIC DISCHARGE (ESD)	16
6.2.1	<i>E.U.T. Operation</i>	17
6.2.2	<i>Block Diagram of Setup</i>	17
6.2.3	<i>Direct Discharge Test Results</i>	18
6.2.4	<i>Indirect Discharge Test Results</i>	18
6.3	RADIO-FREQUENCY ELECTROMAGNETIC FIELDS, 80MHZ TO 1GHZ	18
6.3.1	<i>E.U.T. Operation</i>	19
6.3.2	<i>Block Diagram of Setup</i>	19
6.3.3	<i>Test Results</i>	20
7	PHOTOGRAPHS – TEST SETUP	21
7.1	PHOTOGRAPH – RADIATED ELECTROMAGNETIC DISTURBANCE TEST SETUP, 9KHZ TO 30MHZ	21
7.2	PHOTOGRAPH – RADIATED EMISSION TEST SETUP, 30MHZ TO 300MHZ	21
7.3	PHOTOGRAPH – ESD IMMUNITY TEST SETUP	22
7.4	PHOTOGRAPH – RADIO-FREQUENCY ELECTROMAGNETIC FIELDS IMMUNITY TEST SETUP	22
8	PHOTOGRAPHS – CONSTRUCTIONAL DETAILS	23
8.1	EUT – FRONT VIEW	23
8.2	EUT – INTERNAL VIEW	26

3 General Information

3.1 General Description of E.U.T.

Product Name : Thumb up keyring with LED light
Model No. : MO8940
Remark..... : ---

3.2 Details of E.U.T.

Technical Data..... : DC 4.5V

3.3 Description of Support Units

The EUT has been tested as an independent unit. MO8940 is the test sample. All tests were performed In the condition of DC 4.5V input.

3.4 Standards Applicable for Testing

The tests were performed according to following standards:

EN 55015:2013+A1:2015	Limits and methods of measurement of radio disturbance characteristics of electrical lighting and similar equipment
EN 61547:2009	Equipment for general lighting purposes — EMC immunity requirements



3.5 Test Facility

The test facility has a test site registered with the following organizations:

- **IC – Registration No.: 21895-1**

Waltek Services (Foshan) Co., Ltd. has been registered and fully described in a report filed with the Industry Canada. The acceptance letter from the Industry Canada is maintained in our files. Registration IC number:21895-1, Nov. 14, 2016.

- **FCC – Registration No.: 820106**

Waltek Services (Foshan) Co., Ltd. EMC Laboratory has been registered and fully described in a report filed with the (FCC) Federal Communications Commission. The acceptance letter from the FCC is maintained in our files. Registration 820106, August 16, 2018

- **NVLAP – Lab Code: 600191-0**

Waltek Services (Foshan) Co., Ltd. EMC Laboratory is accredited by the National Voluntary Laboratory Accreditation Program (NVLAP/NIST). NVLAP Code: 600191-0.

This report must not be used by the client to claim product certification, approval, or endorsement by NVLAP, NIST, or any agency of the Federal Government.

3.6 Subcontracted

Whether parts of tests for the product have been subcontracted to other labs:

Yes No

If Yes, list the related test items and lab information:

Test items: ---

Lab information: ---

3.7 Abnormalities from Standard Conditions

None.

4 Equipment Used during Test

Radiated electromagnetic disturbance(9kHz to 30MHz)					
Item	Equipment	Manufacturer	Model No.	Serial No.	Calibration Status
1.	EMI Test Receiver	R&S	ESCI	101178	Valid
2	Three Loops Antenna	SCHWARZBECK	HXYZ9170	213	Valid
Radiated Emission					
Item	Equipment	Manufacturer	Model No.	Serial No.	Calibration Status
1.	EMI Test Receiver	R&S	ESR7	101566	Valid
2.	Active Loop Antenna	SCHWARZBECK	FMZB1519B	00004	Valid
3.	Trilog Broadband Antenna	SCHWARZBECK	VULB 9162	9162-117	Valid
4.	Preamplifier	SCHWARZBECK	BBV 9743	BBV 9743#170	Valid
ESD					
Item	Equipment	Manufacturer	Model No.	Serial No.	Calibration Status
1.	ESD Simulator	TESEQ	NSG437	521	Valid
Radio-frequency electromagnetic fields					
Item	Equipment	Manufacturer	Model No.	Serial No.	Calibration Status
1.	RF Power Amplifier	OPHIR	5225R	1051/1712	Valid
2.	RF Power Amplifier	OPHIR	5293RE	1051/171.	Valid
3.	Stacked double logarithmic periodic antenna	SCHWARZBECK	STLP9128E-SPECIAL	STLP 9128E	Valid
4.	Stacked double logarithmic periodic antenna	SCHWARZBECK	STLP 9149	STLP 9149 #476	Valid
5.	RF signal generator	Agilent	N5181A	MY48080720	Valid

4.1 Measurement Uncertainty

Test Item	Frequency Range	Uncertainty	Note
Mains Terminal Disturbance Voltage	150kHz~30MHz	±2.66dB	(1)
Radiated electromagnetic disturbance	9kHz to 30MHz	±3.00dB	(1)
Radiated Emission	30MHz~300MHz	±4.56dB	(1)

(1) This uncertainty represents an expanded uncertainty expressed at approximately the 95% confidence level using a coverage factor of $k=2$.



5 Emission Test Results

5.1 Radiated Electromagnetic Disturbance, 9kHz to 30MHz

Test Requirement..... : EN 55015 Clause 4.4.1
Test Method..... : EN 55015 Clause 9.1
Test Result..... : Pass
Frequency Range..... : 9kHz to 30MHz
Class/Severity..... : Table 3a of EN55015

5.1.1 E.U.T. Operation

Operating Environment:

Temperature : 24.8°C
Humidity..... : 49.3%RH
Barometric Pressure..... : 101.2kPa

EUT Operation:

Input Voltage : DC 4.5V
Operating Mode..... : Lighting mode

5.1.2 Block Diagram of Test Setup

The Radiated Electromagnetic Disturbance (9kHz to 30MHz) test was performed in accordance with the EN 55015.

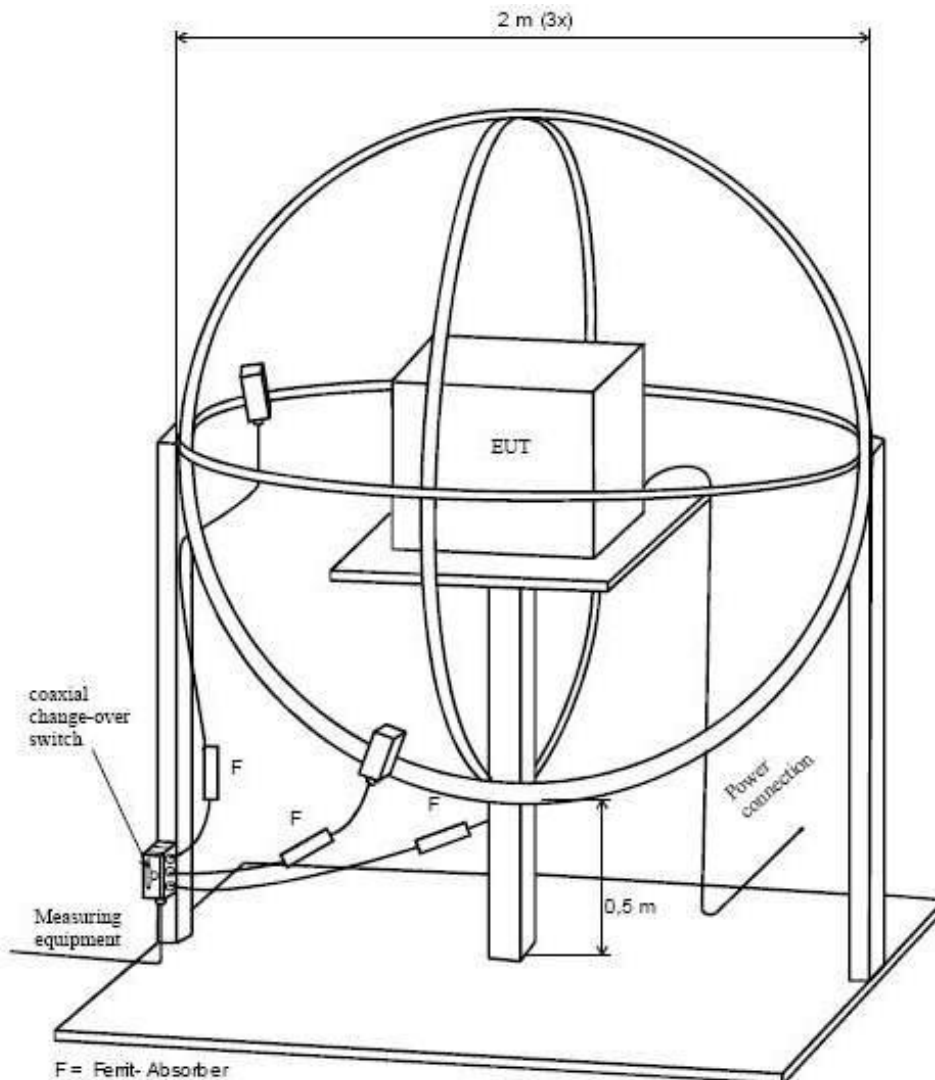

5.1.3 Measurement Data

According to the data in section 5.2.4, the EUT complied with the EN55015 standards.

5.1.4 Radiated Electromagnetic Disturbance test data, 9kHz to 30MHz

Loop X:

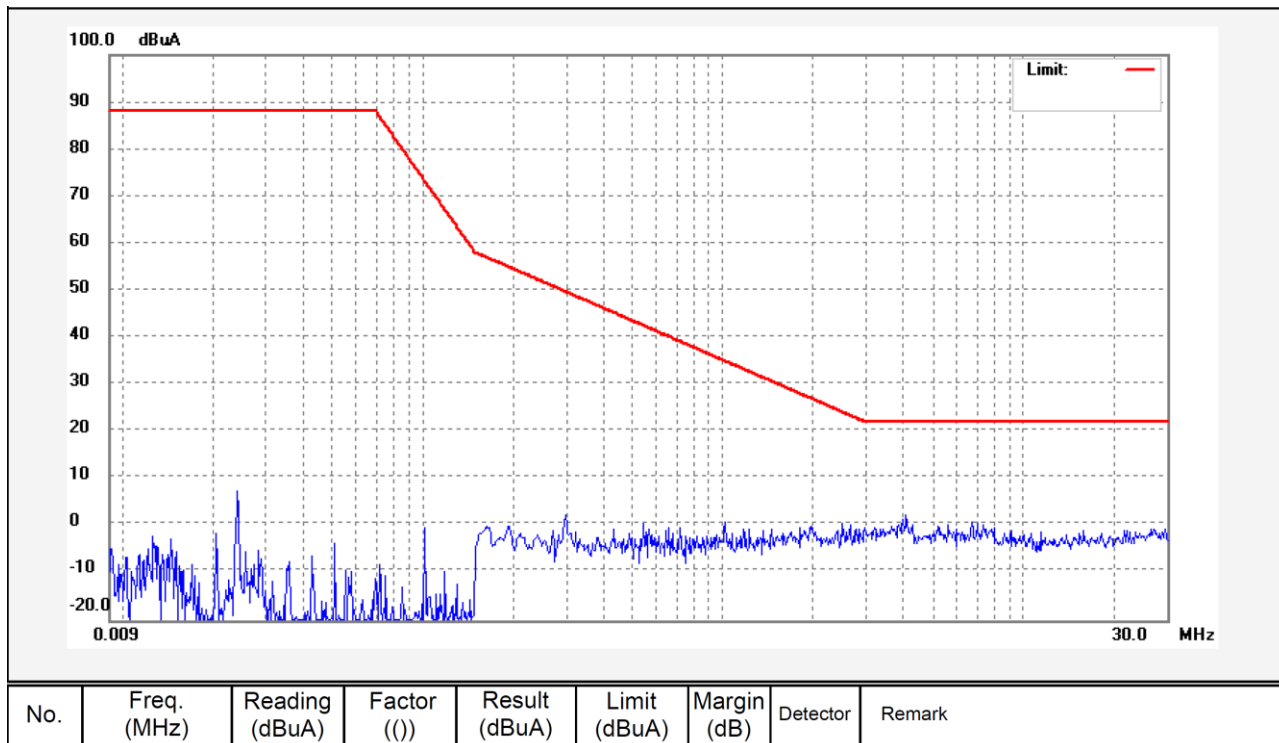



Loop Y:

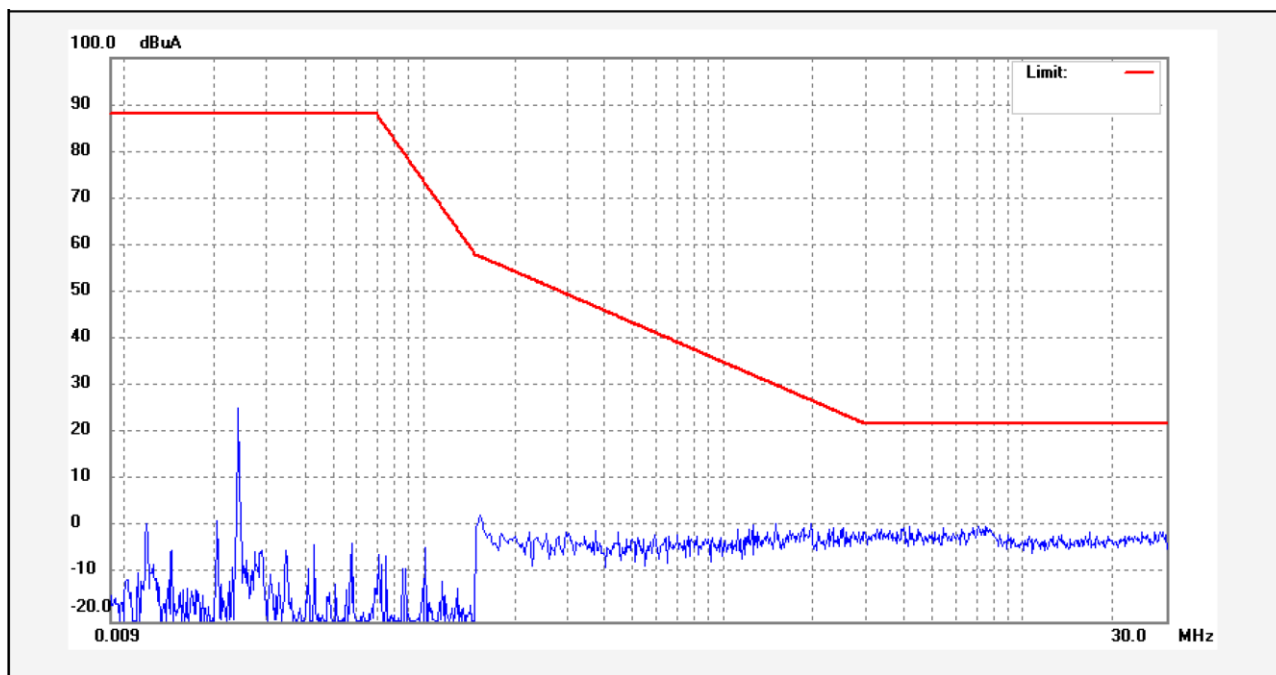

No.	Freq. (MHz)	Reading (dBuA)	Factor (())	Result (dBuA)	Limit (dBuA)	Margin (dB)	Detector	Remark
-----	-------------	----------------	-------------	---------------	--------------	-------------	----------	--------



Loop Z:

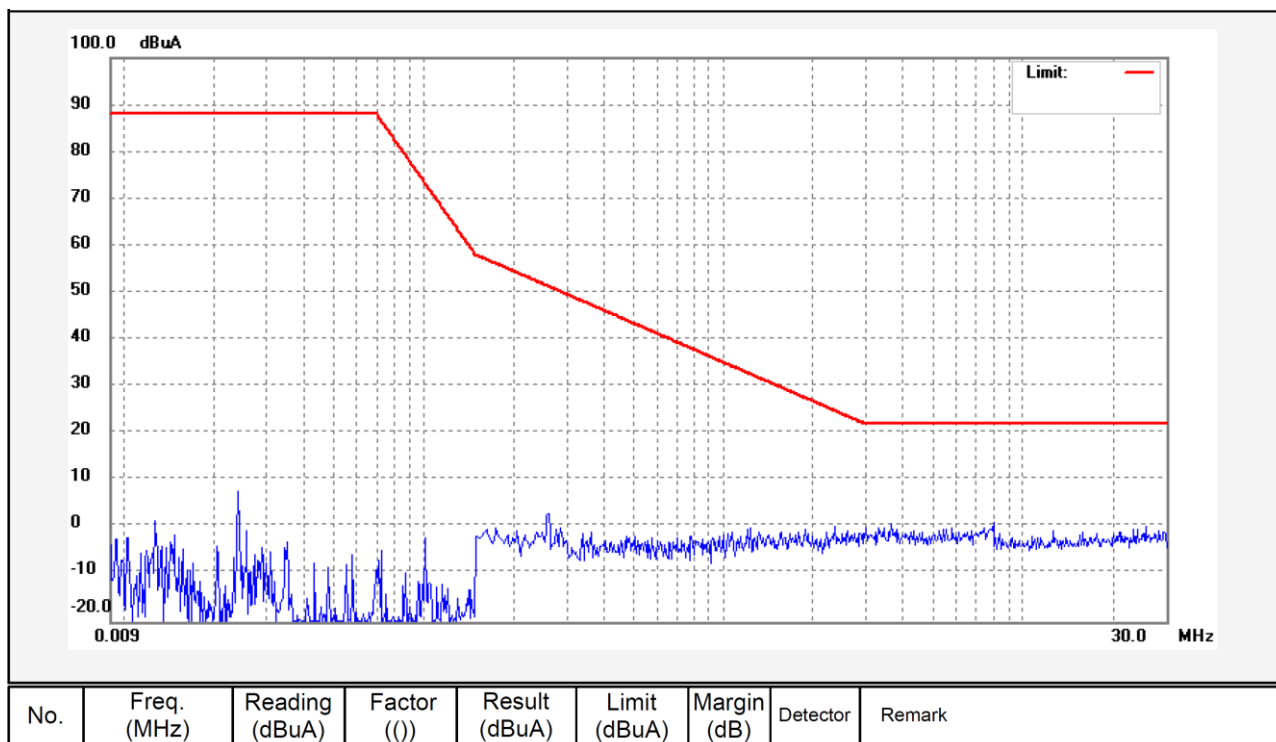

5.2 Radiated Emission, 30MHz to 300MHz

- Test Requirement**..... : EN 55015 Clause 4.4.2
- Test Method**..... : Clause 10 of CISPR 22
- Test Result**..... : Pass
- Frequency Range**..... : 30MHz to 300MHz
- Class/Severity**..... : Table 3b of EN55015

5.2.1 E.U.T. Operation

Operating Environment:

- Temperature** : 23.1°C
- Humidity**..... : 44.9%RH
- Atmospheric Pressure**..... : 101.2kPa

EUT Operation :

- Input Voltage** : DC 4.5V
- Operating Mode**..... : Lighting mode

5.2.2 Block Diagram of Setup

The Radiated Emission test was performed in the 3m Semi- Anechoic Chamber test site and accordance with CISPR16-2-3.

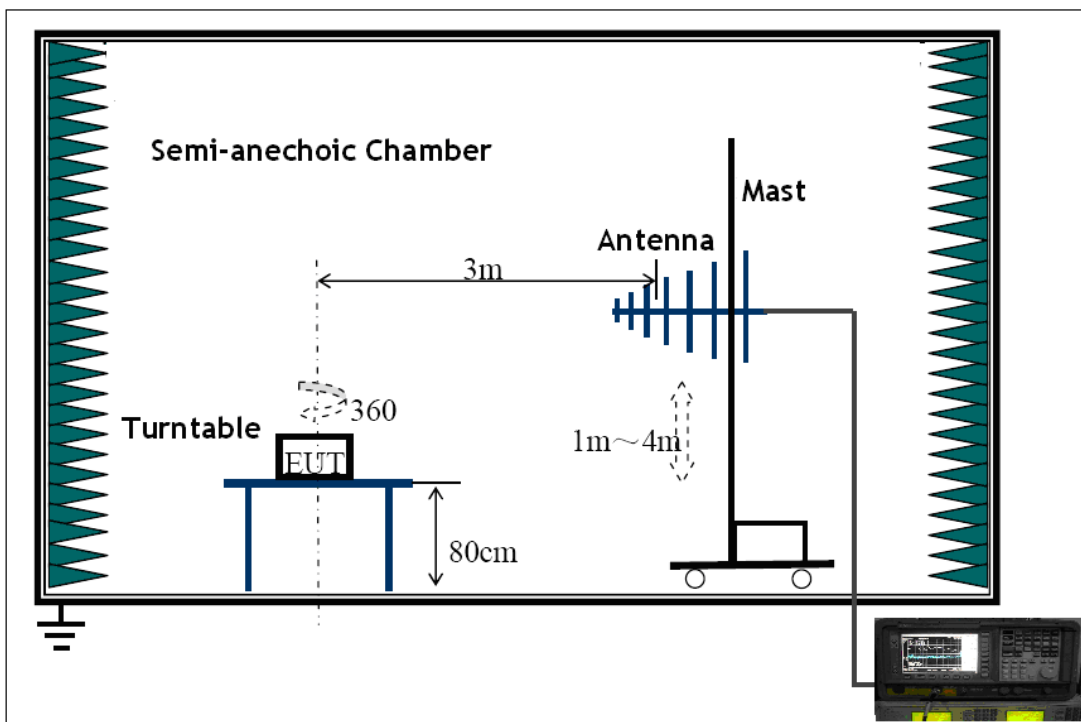



5.2.3 Measurement Data

The maximised peak emissions from the EUT was scanned and measured for Horizontal & Vertical polarisation. Quasi-peak measurements were performed if peak emissions were within 6dB of the limit line.

5.2.4 Radiated Emission Test Data

Vertical Polarization:

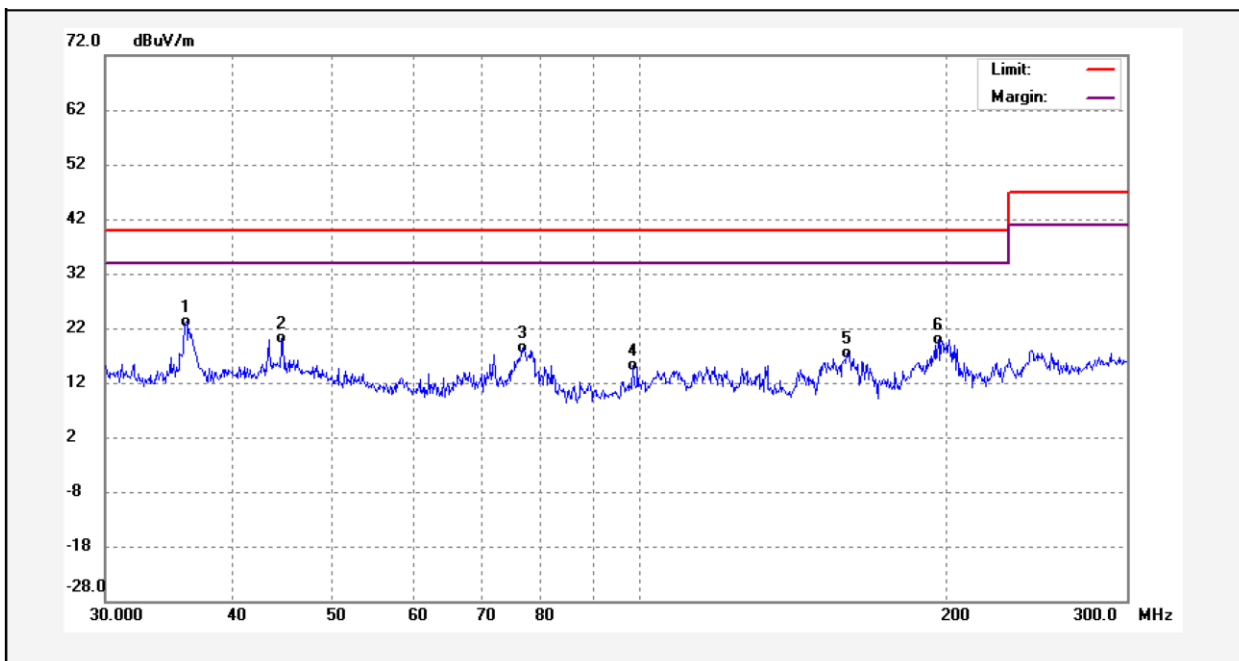

No.	Freq. (MHz)	Reading (dBuV/m)	Factor (dB)	Result (dBuV/m)	Limit (dBuV/m)	Margin (dB)	Detector	Remark
1	35.9850	9.23	13.93	23.16	40.00	-16.84	QP	
2	44.6808	4.13	15.89	20.02	40.00	-19.98	QP	
3	76.7576	10.14	8.32	18.46	40.00	-21.54	QP	
4	98.4286	4.04	11.20	15.24	40.00	-24.76	QP	
5	159.6325	8.79	8.61	17.40	40.00	-22.60	QP	
6	195.9391	8.43	11.51	19.94	40.00	-20.06	QP	

Horizontal Polarization :

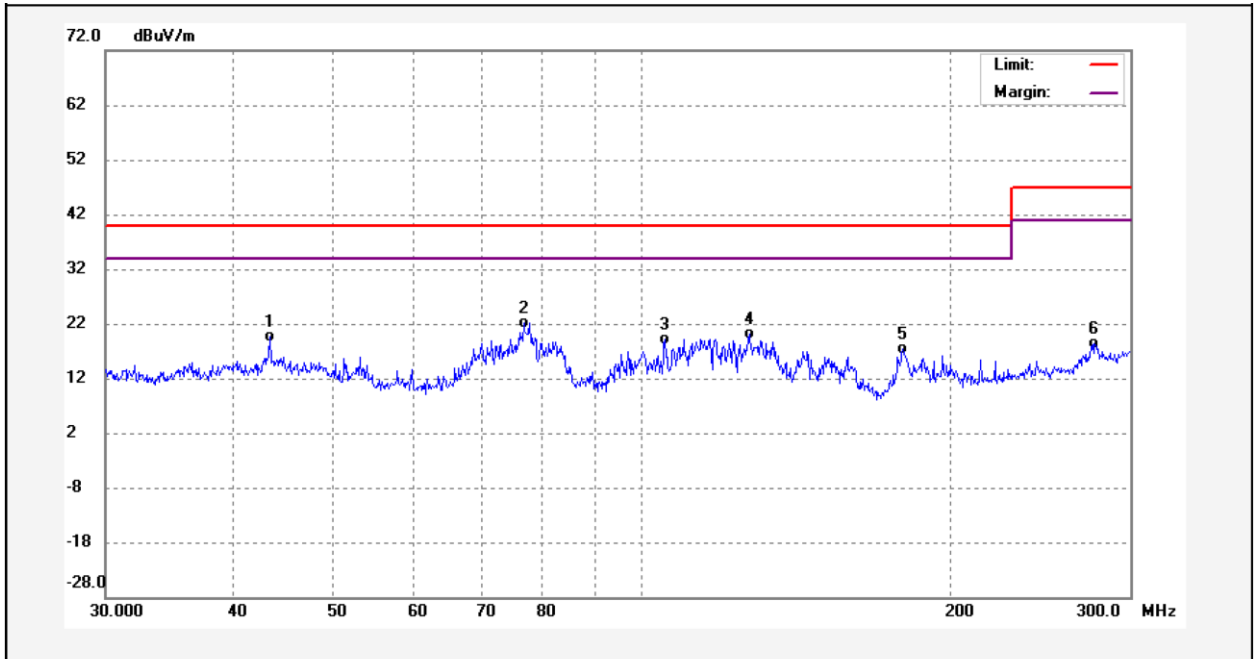

No.	Freq. (MHz)	Reading (dBuV/m)	Factor (dB)	Result (dBuV/m)	Limit (dBuV/m)	Margin (dB)	Detector	Remark
1	43.4632	3.66	16.02	19.68	40.00	-20.32	QP	
2	76.7576	13.75	8.37	22.12	40.00	-17.88	QP	
3	105.4681	6.93	12.19	19.12	40.00	-20.88	QP	
4	127.3859	9.38	10.75	20.13	40.00	-19.87	QP	
5	179.9372	7.57	9.86	17.43	40.00	-22.57	QP	
6	276.7714	3.57	14.87	18.44	47.00	-28.56	QP	

6 Immunity Test Results

6.1 Performance Criteria

Performance criterion A: During the test, no change of the luminous intensity shall be observed and the regulating control, if any, shall operate during the test as intended.

Performance criterion B: During the test, the luminous intensity may change to any value. After the test, the luminous intensity shall be restored to its initial value within 1 min. Regulating controls need not function during the test, but after the test, the mode of the control shall be the same as before the test provided that during the test no mode changing commands were given.

Performance criterion C: During and after the test, any change of the luminous intensity is allowed and the lamp(s) may be extinguished. After the test, within 30 min, all functions shall return to normal, if necessary by temporary interruption of the mains supply and/or operating the regulating control.

6.2 Electrostatic Discharge (ESD)

Test Requirement	:	EN 61547
Test Method	:	IEC 61000-4-2
Test Result	:	Pass
Discharge Impedance	:	330Ω / 150pF
Discharge Voltage	:	Air Discharge: ±8kV Contact Discharge: ±4kV HCP & VCP: ±4kV
Polarity	:	Positive & Negative
Number of Discharge	:	Minimum 10 times at each test point
Discharge Mode	:	Single Discharge
Discharge Period	:	1 second minimum

6.2.1 E.U.T. Operation

Operating Environment:

- Temperature : 23.3°C
- Humidity : 46.4%RH
- Barometric Pressure : 100.2kPa

EUT Operation:

- Input Voltage : DC 4.5V
- Operating Mode : On mode

6.2.2 Block Diagram of Setup

The ESD test was performed in accordance with the IEC 61000-4-2.

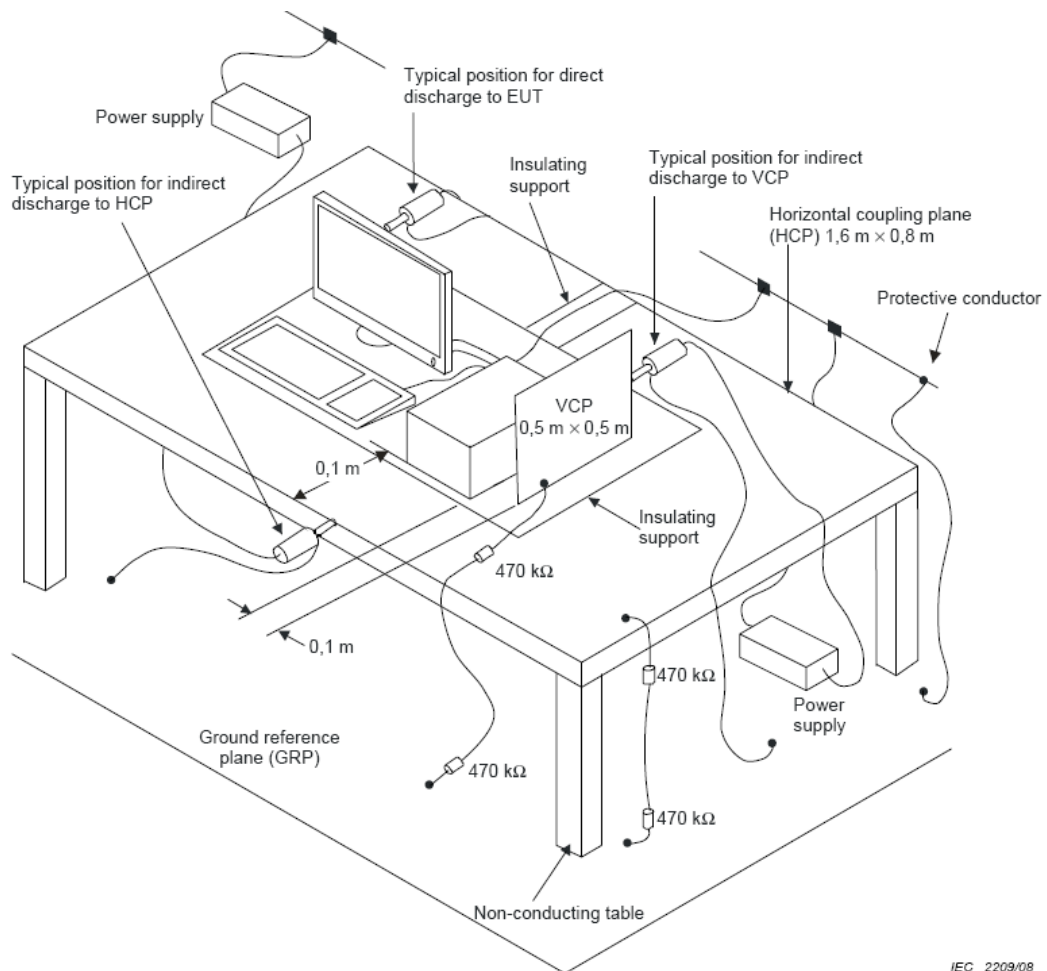

6.3.1E.U.T. Operation

Operating Environment:

- Temperature : 23.3°C
- Humidity..... : 46.4%RH
- Barometric Pressure..... : 100.2kPa

EUT Operation:

- Input Voltage : DC 4.5V
- Operating Mode..... : On mode

6.3.2 Block Diagram of Setup

The Radio-frequency electromagnetic fields Immunity test was performed in accordance with the IEC 61000-4-3.

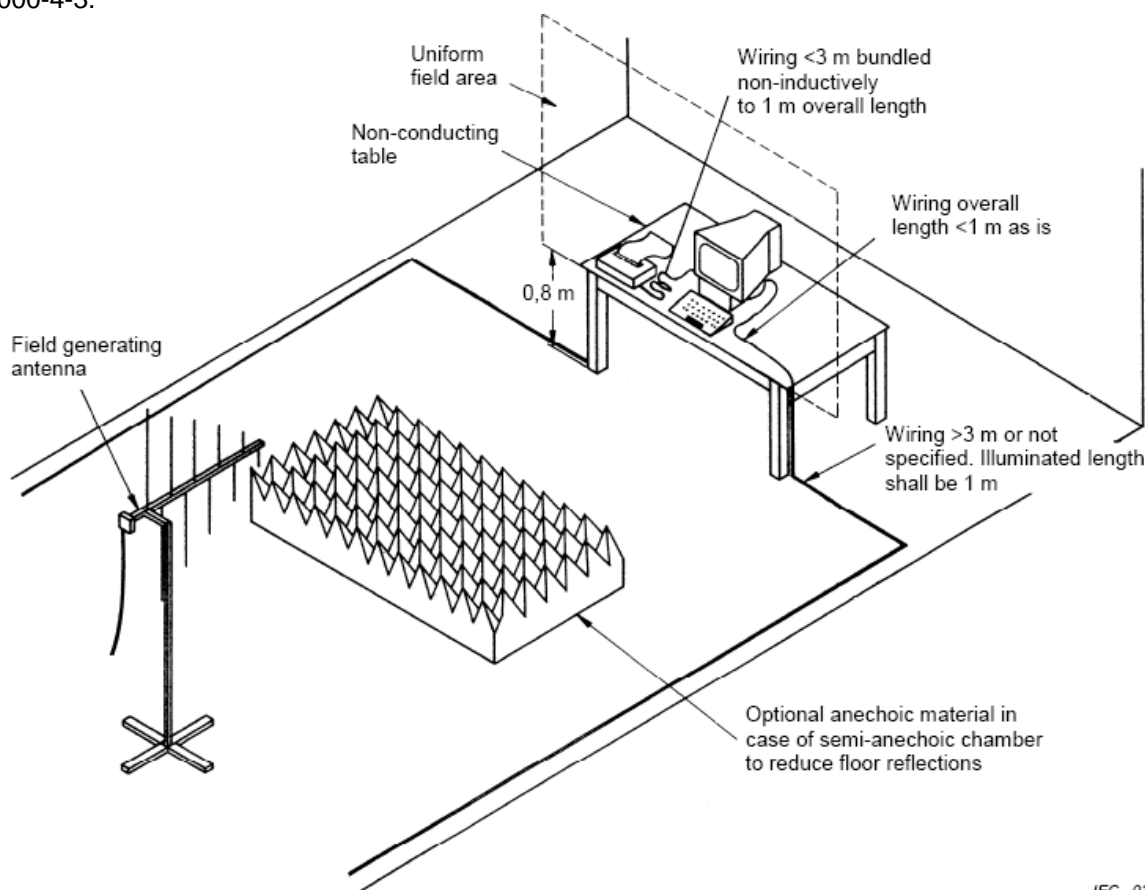

6.3.3 Test Results

Frequency	Face of EUT	Antenna polarisation	Test Level	Step Size	Dwell Time	Performance Criterion	Result
80 to 1000MHz	Front, Back, Left, Right	Horizontal	3V/m	1%	1s	A	Pass*
80 to 1000MHz	Front, Back, Left, Right	Vertical	3V/m	1%	1s	A	Pass*

Remark:

- * During the test no deviation was detected to the selected operation mode(s)

7 Photographs – Test Setup

7.1 Photograph – Radiated electromagnetic disturbance Test Setup, 9kHz to 30MHz



7.2 Photograph – Radiated Emission Test Setup, 30MHz to 300MHz

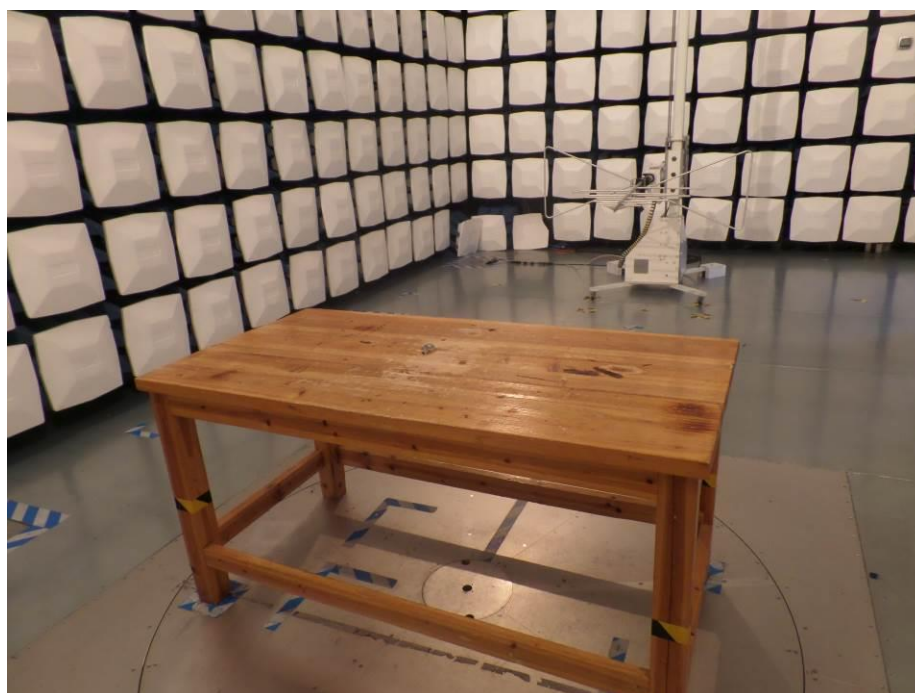

7.3 Photograph – ESD Immunity Test Setup

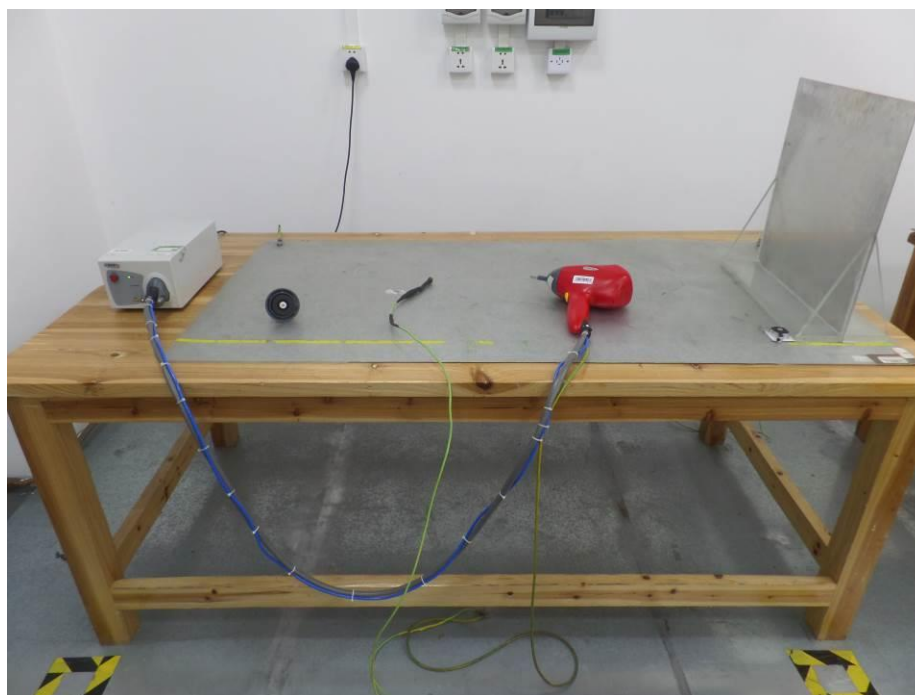

7.4 Photograph – Radio-frequency electromagnetic fields Immunity Test Setup

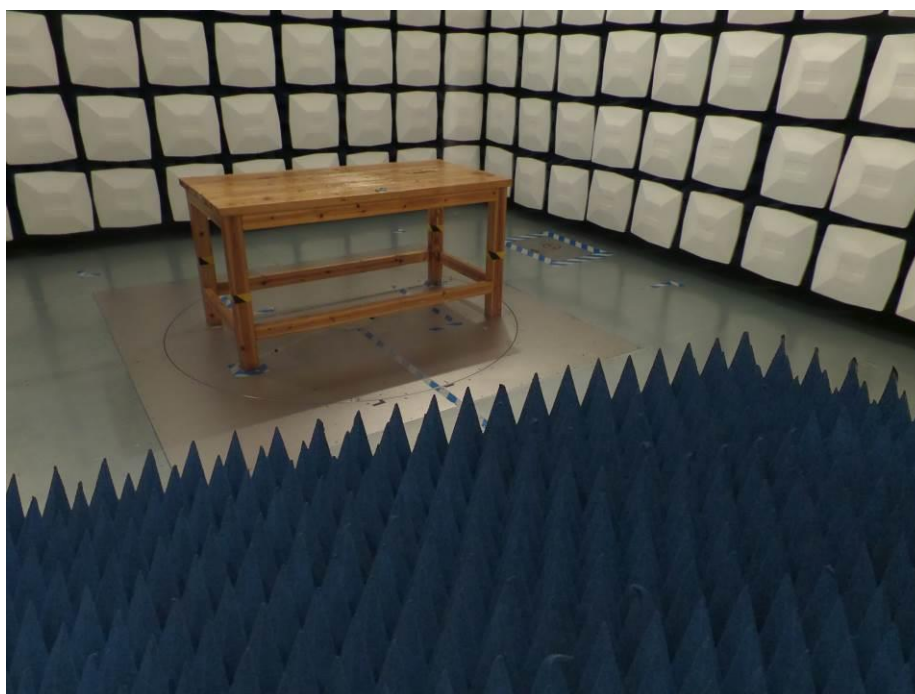

8 Photographs – Constructional Details

8.1 EUT – Front View







8.2 EUT – Internal View



==== End of Report =====